

Warranty

Chris King Precision Components warrants its bicycle bottom brackets to be free from defects in materials or workmanship for a period of 5 years from the original date of purchase. Any Chris King product that is found by Chris King Precision Components to be defective in materials or workmanship will be repaired or replaced at the sole discretion of Chris King Precision Components providing it is returned to the factory freight prepaid. This warranty does not cover damage or failure resulting from misuse, abuse, alteration, neglect, normal and reasonable wear and tear, crash or impact, failure to perform routine maintenance as instructed, or use other than that for which the product was intended.

If a defect is found, our entire liability and your sole remedy shall be, at our option, free repair or replacement of the Chris King product. Chris King Precision Components shall not be held liable for any indirect, special, or consequential damages. The warranty does not cover any Chris King Precision Components product where the serial number has been altered or removed. This written express warranty is in lieu of all other warranties, implied or expressed, and does not cover any representation or warranty made by dealers beyond the provisions of this warranty. This warranty gives you specific legal rights, and you may also have other rights which vary state to state.

Thank you for your purchase!

Made in the USA

All Chris King Precision Components products are manufactured 100% in the USA using industry leading environmental and quality control standards.

All trademarks, registered trademarks, and logos are of their respective holders.

© King Cycle Group, 2011. All rights reserved.

Chris King Precision Components™

2801 NW Nela Street, Portland, Oregon 97210
800.523.6008 | www.chrisking.com | info@chrisking.com



Printed with soy ink. Contains 100% post consumer recycled paper fiber.
rev. 04/12-A

Bottom Bracket

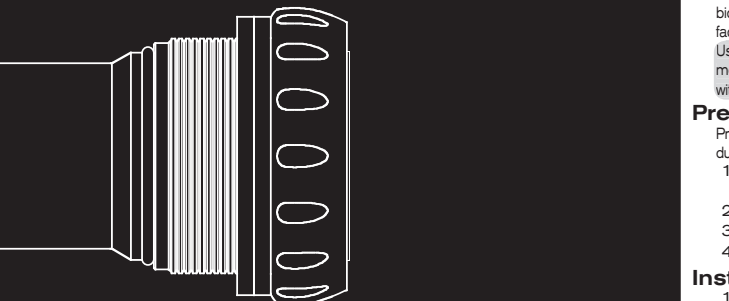

CHRIS KING
PRECISION COMPONENTS

Installation of 24mm Stepped Spindle Bottom Bracket

Bottom bracket (BB) installation requires specialized tools. We recommend the procedure be performed by a qualified professional bicycle mechanic. To ensure proper installation, the use of high quality facing and thread chasing tooling is strongly recommended.

Use BB marked MTN (A) on 68, 73, 83mm BB center sleeves with mountain-style cranks. Use BB marked ROAD (B) on 68mm BB shells with road-style cranks.

24mm Stepped Spindle BB Compatibility & Specs	
BB shell width	68 mm, 73 mm, 83mm (83mm center sleeve is an aftermarket item)
crankset design	compatible with most SRAM™ GXP™, Truvativ™ and Bontrager™ external BB configurations that use a 24mm stepped crank spindle
front derailleur	seat tube mounted, E-Type (BB mounted)
chain guide	ISCG tab mounted, BB mounted
BB thread type	english
BB weight	stainless steel bearings 120g, ceramic bearings 113g (complete assy, without BB cup spacers, 2.5g each)

Preparation of Bottom Bracket Shell

Proper preparation of the BB shell is required for best BB performance, durability, longevity and reduces the possibility of installation problems.

- Chase the BB shell threads to ensure that threads are properly formed.
- Face the BB shell to ensure that the ends are square and parallel to each other. Be sure to remove all frame paint from BB shell/BB cup interface.
- Use a small file, deburring tool or sand paper, carefully remove any sharp edges or burrs from the BB shell edges.
- Clean BB shell threads and surfaces to remove any chips, shavings, and/or cutting oil.

Installation of bearing cups

- Note BB cup orientation marking on BB threads before applying anti-seize to threads, as marking may be obscured when anti-seize is applied to threads. Apply a generous coating of anti-seize (use Zinc-based anti-seize when installing onto a titanium frame) to the threads on the BB cups, as well as on the BB shell threads on the bicycle frame.
- Make sure that the double O-ring side of the center sleeve is pressed into either BB cup, seating the inner O-ring on the inner edge of the BB cup.

Stepped Spindle BB assembly

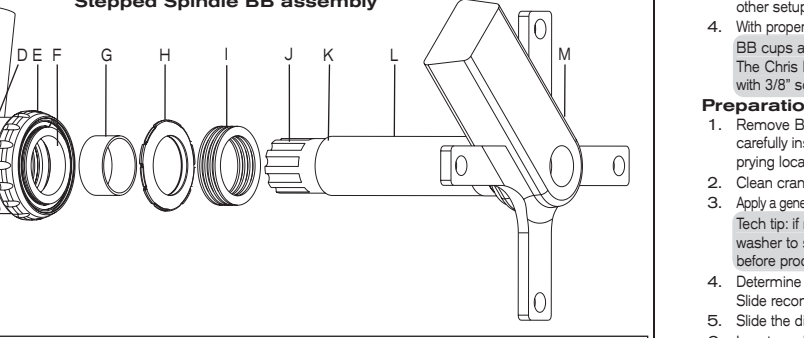

- A. crank arm, non-driveside
- B. adaptor washer
- C. BB cup assy, non-driveside
- D. bicycle frame BB shell
- E. BB cup assembly, drive side
- F. bearing spindle sleeve
- G. adaptor sleeve
- H. disc spring
- I. spindle spacers (4 pictured)
- J. spindle splines
- K. spindle step/shoulder
- L. crank spindle
- M. crank arm assy, drive side

- If installing a MTB-style BB and crankset into a 68 mm BB shell, install one 2.5 mm BB cup spacer onto each bearing cup. No spacers are required for all other setup configurations.
- With proper BB spacers installed on BB cups, thread BB cups into frame using a compatible BB cup spline tool (see below) and torque to 40 Nm (30 ft/lbs). BB cups are compatible with the following external BB cup spline tools: Chris King External BB Cup Tool, Park™ BBT-9 and Shimano™ TL-FC32/TL-FC33. The Chris King External BB Cup Tool features an optimized spline interface that minimizes the chance of marring BB cup anodization and is compatible with 3/8" socket wrenches and torque wrenches.

Preparation and fitting of crank spindle

- Remove BB bearing spindle sleeves (black plastic pieces) from the inner diameter of both bottom bracket bearings by hand. If not removable by hand, carefully insert the tip of a small screwdriver or penknife under outer flange of BB bearing spindle sleeve and gently pry it out of the bearing using alternating prying locations.
- Clean crank spindle and spline interface and apply grease to splines
- Apply a generous amount of waterproof grease to the inside of the adaptor sleeve, then slide adaptor sleeve over the spindle splines until it sits flush with the shoulder on spindle shaft. Tech tip: if resistance is encountered when sliding adaptor sleeve onto spindle, slide adaptor washer onto splines and apply even pressure to the top of the washer to slide the sleeve up the splines until it sits tightly and evenly against the shoulder on the spindle shaft. Then remove the washer from the spindle before proceeding.
- Determine the recommended number of spindle spacers required for your crankset/BB shell interface by referring to the Spindle Spacer Guide in this manual. Slide recommended number of spindle spacers onto spindle so that they sit flush with the drive side crank interface.
- Slide the disc spring onto spindle.
- Insert crank assembly through drive side of bottom bracket. Note: crank spindle will be loose inside of bearings. This procedure is for fitting only. Do not use cranks without bearing spindle sleeves installed on bottom bracket.
- For an ideal installation, the outer edge of the adaptor sleeve will protrude from the outside edge of the bearing by 0.5 mm. A protrusion of 0 mm to 1 mm is acceptable". If adaptor sleeve measurement falls within the acceptable range, move to Step 10.

10. Once proper fit has been determined, remove crank from bottom bracket and reinstall bearing spindle sleeves into BB bearings. Proceed to "Installation of crankset" section.

Installation of crankset

- Slide spindle through BB on bicycle. Tech note: Spindle should be insertable into BB using hand pressure. Use of a mallet or other excessive force may cause bearing to separate. Before passing spindle through second BB bearing, be sure spindle is properly aligned with the hole through the second bearing. If fitting issues are encountered, contact Chris King Customer Service for assistance at info@chrisking.com or call 800-523-6008.
- Slide adaptor washer onto spindle spline that is protruding through the non-driveside bearing.
- Install non-driveside crankarm by following crank arm manufacturer's installation instructions.
- Check for bearing interface play by pushing/pulling the crank arm toward/away from the frame. Check for excessive bearing drag by spinning crankset. If bearing play or excessive drag is detected, proceed to "Stepped Spindle BB Installation Troubleshooting", other side.

Tech Note: Readjustment of bearing preload may be necessary as bearing breaks in. Check for lateral play in BB/crank set assembly after first hour of use. Recheck periodically during first 100 hours of use. Keeping optimal preload on BB bearings will help maximize their longevity.

Tech Note: every effort has been made to maintain the crank manufacturer's chainline, however some adjustment of the front derailleur may be necessary to achieve proper alignment.

24mm Stepped BB Spindle Spacer Guide (SRAM™ type)

Crankset	BB shell width	BB-Mounted Chainguide or E-Type Derailleur	2.5mm BB Cup Spacers Non-Drive Side	2.5mm BB Cup Spacers Drives Side	1mm Al Spindle Spacers**
road double	68 mm	n/a	0	0	0
road triple*	68 mm	n/a	0	0	5
tandem captain	68 mm	n/a	0	0	0
tandem stoker*	68 mm	n/a	0	0	8
mtn triple, double, and single	68 mm	no	1	1	4
mtn triple, double, and single	68 mm	yes	1	0	4
mtn triple, double, and single	73 mm	no	0	0	4
mtn triple, double, and single	73 mm	yes	0	0	1
mtn triple, double, and single	83mm***	no	1	1	4
mtn triple, double, and single	83mm***	yes	1	0	1

*Requires Spacer Kit (kits includes 4 additional 1mm spacers)
**Fine tune preload with included 0.33mm planistic spindle spacer
***Requires 83mm center sleeve available as an aftermarket item

Congratulations! Since 1976, Chris King has been supplying cyclists with the best made, most reliable components you can buy. With proper installation and maintenance, you can expect to enjoy many years of the legendary quality and performance built into each and every component we make.

24mm Spindle BB Installation

Bottom bracket (BB) installation requires specialized tools. We recommend the procedure be performed by a qualified professional bicycle mechanic. To ensure proper installation, the use of high quality facing and thread chasing tooling is strongly recommended.

Use BB marked MTN (A) on 68, 73, 83 and 100mm BB center sleeves with mountain-style cranks. Use BB marked ROAD (B) on 68mm BB shells with road-style cranks. *Some FSA road cranks require the use of the MTN (A) cups. *Shimano DXR cranks use MTN (A) cups with one drive side cup spacer.

Preparation of Bottom Bracket Shell

Proper preparation of the BB shell is required for best BB performance, durability, longevity and reduces the possibility of installation problems.

- Chase the BB shell threads to ensure that threads are properly formed.
- Face the BB shell to ensure that the ends are square and parallel to each other. Be sure to remove all frame paint from BB shell/BB cup interface.
- Using a small file, deburring tool or sand paper, carefully remove any sharp edges or burrs from the BB shell edges.
- Clean BB shell threads and surfaces to remove any chips, shavings, and/or cutting oil.

Installation of Bearing Cups

- Note BB cup orientation marking on BB threads before applying anti-seize to threads, as marking may be obscured when anti-seize is applied to threads. Apply a

generous coating of anti-seize (use Zinc-based anti-seize when installing onto a titanium frame) to the threads on the BB cups, as well as on the BB shell threads on the bicycle frame.

- Follow crank arm manufacturer's instructions to determine proper BB cup spacer orientation. Proper spacer configuration is essential for correct bearing preload, chain line and crank arm positioning. Note: if using a 68mm BB shell with 0 or 1 2.5mm BB cup spacers, move center sleeve inner O-ring to inner groove on center sleeve. See exploded BB diagram for details. Some crank set designs may require additional spindle spacers to be installed onto the crank arm spindle to achieve proper BB bearing preload. Three spindle spacers are included and are only required when dealing with undersized BB shells, oversized crank arm spindle lengths, and other BB spacing inconsistencies. Additional spacer kits are available through any authorized Chris King dealer, or directly from Chris King. Make sure that the double O-ring side of the center sleeve is pressed into either BB cup, seating the inner O-ring on the inner edge of the BB cup.

- With proper BB spacers installed on BB cups, thread BB cups into frame using a compatible BB cup spline tool (see below) and torque to 40Nm (30 ft/lbs). BB cups are compatible with the following external BB cup spline tools: Chris King External BB Cup Tool, Park™ BBT-9 and Shimano™ TL-FC32/TL-FC33. The Chris King External BB Cup Tool features an optimized spline interface that minimizes the chance of marring BB cup anodization and is compatible with 3/8" socket wrenches and torque wrenches.

- Clean crank spindle and apply a thin layer of grease to spindle surface.

Spindle should be insertable into BB using hand pressure. Use of a mallet or other excessive force may cause bearing to separate. If fitting issues are encountered, contact Chris King Customer Service for assistance at info@chrisking.com or call 800-523-6008.

- Before passing spindle through second BB bearing, be sure spindle is properly aligned with BB bearing spindle sleeve. Follow crank arm manufacturer's installation instructions to properly install crank assembly and achieve optimal BB bearing preload.

- Check for bearing play by pushing/pulling the crank arm toward/away from the frame. To eliminate bearing play, confirm proper spacer orientation and readjust bearing preload.

Readjustment of bearing preload may be necessary as bearing breaks in. Check for lateral play in BB/crank set assembly after first hour of use. Recheck periodically during first 100 hours of use. Keeping optimal preload on BB bearings will help maximize their longevity.

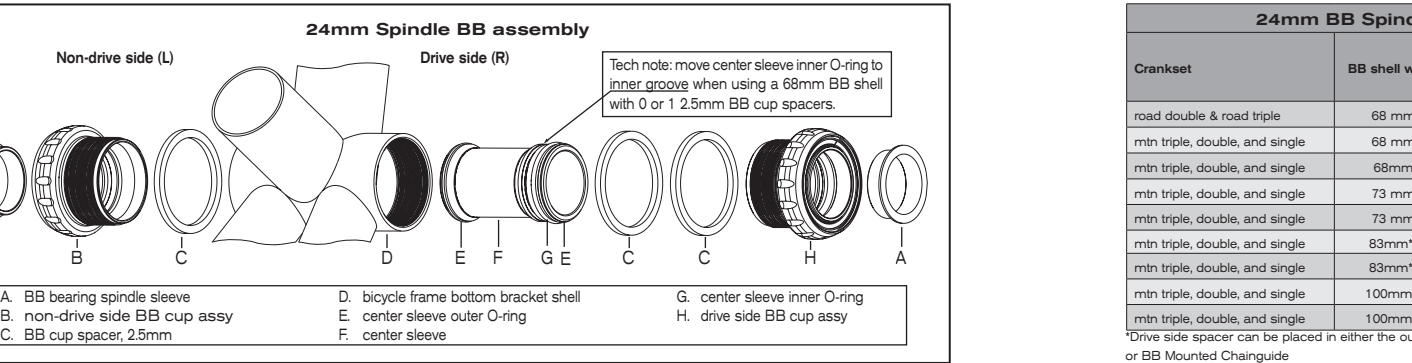

Readjustment of bearing preload may be necessary as bearing breaks in. Check for lateral play in BB/crank set assembly after first hour of use. Recheck periodically during first 100 hours of use. Keeping optimal preload on BB bearings will help maximize their longevity.

24mm BB Spindle Spacer Guide (Shimano™ Type)				
Crankset	BB shell width	BB - Mounted Chainguide or E-Type Derailleur	Number of 2.5mm Spacers Non-Drive Side	Number of 2.5mm Spacers Drive Side
road double & road triple	68 mm	n/a	0	0
mtn triple, double, and single	68 mm	no	1	2
mtn triple, double, and single	68mm	yes	1	1*
mtn triple, double, and single	73 mm	no	0	1
mtn triple, double, and single	73 mm	yes	0	0
mtn triple, double, and single	83mm**	no	Please consult crank manufacturer's installation instructions for proper installation	
mtn triple, double, and single	83mm**	yes		
mtn triple, double, and single	100mm**	no		
mtn triple, double, and single	100mm**	yes		

*Drive side spacer can be placed in either the outer or inner position in order to establish the best set up for E-Type Derailleur or BB Mounted Chainguide

**Requires either the 83mm or 100mm BB center sleeve. They are available as aftermarket items.

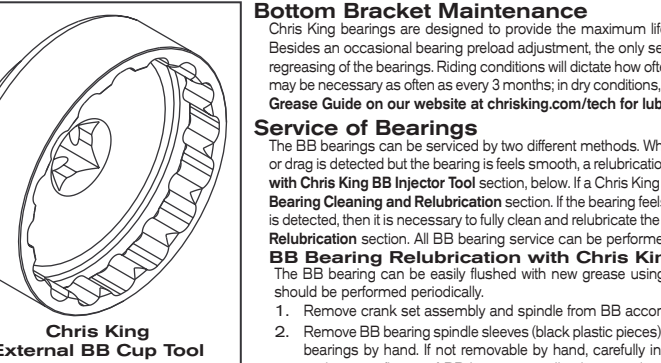

Chris King External BB Cup Tool

Bottom Bracket Maintenance

Chris King bearings are designed to provide the maximum life of any BB with a minimum of maintenance. Besides an occasional bearing preload adjustment, the only service necessary is an occasional cleaning and regreasing of the bearings. Riding conditions will dictate how often to service your BB. In wet conditions, service may be necessary as often as every 3 months; in dry conditions, up to every 6 months. **See the Bottom Bracket Grease Guide on our website at chrisking.com/tech for lubrication and maintenance interval details.**

Service of Bearings

The BB bearings can be serviced by two different methods. When rotating the inner bearing race, if resistance or drag is detected but the bearing is feels smooth, a relubrication is due. Proceed to **BB Bearing Relubrication with Chris King BB Injector Tool** section, below. If a Chris King BB Injector Tool is not available, proceed to **BB Bearing Cleaning and Relubrication** section. If the bearing feels gritty, contaminated, or if significant resistance is detected, then it is necessary to fully clean and relubricate the bearing. Proceed to **BB Bearing Cleaning and Relubrication** section. All BB bearing service can be performed with the BB mounted to the bicycle frame.

BB Bearing Relubrication with Chris King BB Injector Tool

- The BB bearing can be easily flushed with new grease using the Chris King BB Injector Tool. This service should be performed periodically.
- Remove crank set assembly and spindle from BB according to crank set manufacturer's instruction.
 - Remove BB bearing spindle sleeves (black plastic pieces) from the inner diameter of both bottom bracket bearings by hand. If not removable by hand, carefully insert the tip of a small screwdriver or penknife under outer flange of BB bearing spindle sleeve and gently pry it out of the bearing using alternating prying locations.
 - Insert BB Injector Tool into bearing

- Attach grease gun tip to grease fitting on BB Injector Tool
- While continuously pressing the BB Injector Tool into the bearing to form a seal, slowly pump small amounts of synthetic waterproof grease into the bearing. Between pumps, turn the bearing by rotating the injector tool back and forth. This motion allows the new grease to be evenly distributed within the bearing, and completely purges the old grease and contaminants through the front seal. This motion also helps prevent the black rubber seal from accidentally dislodging. If the seal dislodges, remove the bearing snap ring and then follow steps 8 and 9 in the **BB Bearing Cleaning and Relubrication** section.
- Wipe purged grease from bearing surface
- Reinstall bearing spindle sleeve by pressing the sleeve back into bearing's inner race by hand

BB Bearing Cleaning and Relubrication

- Remove crank set assembly and spindle from BB according to crank set manufacturer's instruction.
- Remove BB bearing spindle sleeves (black plastic pieces) from the inner diameter of both bottom bracket bearings by hand. If not removable by hand, carefully insert the tip of a small screwdriver or penknife under outer flange of BB bearing spindle sleeve and gently pry it out of the bearing using alternating prying locations.
- Carefully, using a small screwdriver, pick, or penknife, remove the snap ring by inserting tool into split of snap ring. Gently work one end of the snap ring toward bearing center until it is out of its groove. Follow the ring around with the tool until the snap ring is completely dislodged.
- Lift and remove exposed rubber seal to access the interior of the bearing.
- Thoroughly flush the bearing with a light spray lubricant (e.g., WD-40™) and blow dry with compressed air. Some solvents, synthetic lubricants, and greases with high-pressure additives may attack and damage seals and other nonmetallic materials. Minimize exposure to these substances and thoroughly dry bearing assembly after cleaning.

- If a Chris King BB Injector Tool is available, proceed to **BB Bearing Relubrication with Chris King BB Injector Tool** section and follow steps 3 through 6, then proceed to step 7, below. If an injection tool is not available, proceed to step 6.

- For BBs with stainless steel ball bearings, apply a bead (approx .3ml) of waterproof synthetic grease around the top of the bearing. For BBs with ceramic ball bearings, apply enough grease to lightly coat the balls inside the bearing, using approximately .1ml (a pea-sized amount) of waterproof synthetic lightweight grease. This can be accomplished by applying a light bead of grease 1/8 to 1/4 of the way around the bearing. Rotate the inner race to work grease throughout the ball area. **See the Bottom Bracket Grease Guide at chrisking.com/tech for details.**
- Wipe dirt and other contaminants from the seals and snap rings. Used snap rings and seals can be reinstalled unless warped, punctured, or otherwise damaged. If damaged, replacement seals and snap rings are available through any authorized Chris King dealer or directly from Chris King.
- Replace rubber seal between inner and outer bearing race.
- Insert one edge of snap ring into groove of outer bearing race. Press along entire groove until snap ring is fully seated; a small gap should be visible between both ends of the snap ring.

Stepped Spindle BB Installation Troubleshooting

- If play is detected in bearing interface, add one white plastic spindle spacer between the drive side crank interface and the disc spring. Reinstall crank assembly and retest for bearing play. Repeat as necessary.
- Reinstall crank set according to crank set manufacturer's instructions.

Questions? Please e-mail us at info@chrisking.com or call the Customer Service hotline at 800-523-6008

Replacement parts can be purchased through any authorized Chris King dealer, or directly from Chris King. Common spare parts are available on the online web store at www.chrisking.com/store.

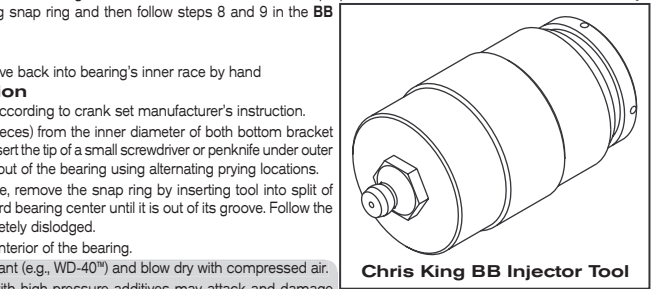

Chris King BB Injector Tool